

ORDERING INFORMATION

Order code: 10037
 Description: BHPS0070/QUADTAP/C/CWI/H/K/STD
 UPC: 69549100374



SPECIFICATIONS

Ballast type: Magnetic high pressure sodium
Ballast style: Core and coil
Circuit type: CWI
ANSI code: S62
Input voltage (V): 120/208/240/347
Input frequency (Hz): 60
Line volt regulation: ± 10 %
Line watt regulation: Within trapezoid
Insulation class: H (180°)

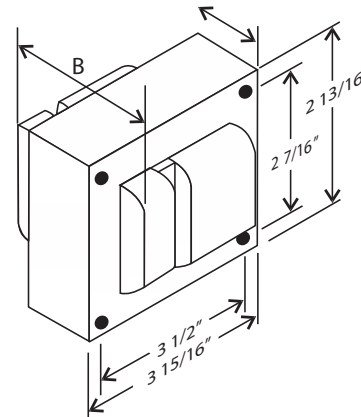

3" x 4" Core



Input voltage (V)	Operating current (A)	Open circuit current (A)	Starting current (A)	Rated lamp watts (W)	Input watts (W)	OCV (V)	Dropout voltage (V)	UL 1029 code	Fuse rating (A)	Input current (A)	Power factor	Starting temperature
120	0.87	0.49	0.49	70	95	110	80	A	3	0.33 - 0.42	0.90	-40°F / -40°C
208	0.50	0.28	0.28	70	95	110	140	A	2	0.18 - 0.24	0.90	-40°F / -40°C
240	0.44	0.24	0.24	70	95	110	160	A	2	0.16 - 0.20	0.90	-40°F / -40°C
347	0.30	0.17	0.17	70	95	110	230	A	1	0.11 - 0.14	0.90	-40°F / -40°C

HIGH POTENTIAL TEST (V)

1 minute:	2 000
2 seconds:	2 500
OCV test:	100 - 125
Short circuit:	2.00 - 2.20

BALLAST DIMENSIONS

Dimension A:	1.78"
Dimension B:	3.10"
Lead Lengths:	12.00"
Weight (lbs):	6.20

WIRING DIAGRAM

Ground ballast core

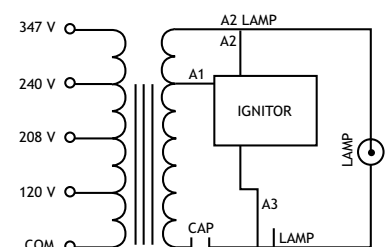

BRACKET

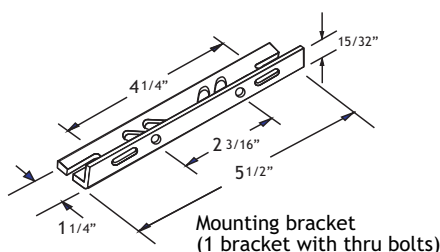

CAPACITOR

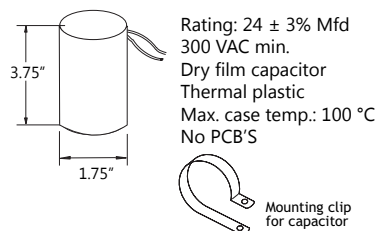

IGNITOR

